

IE2

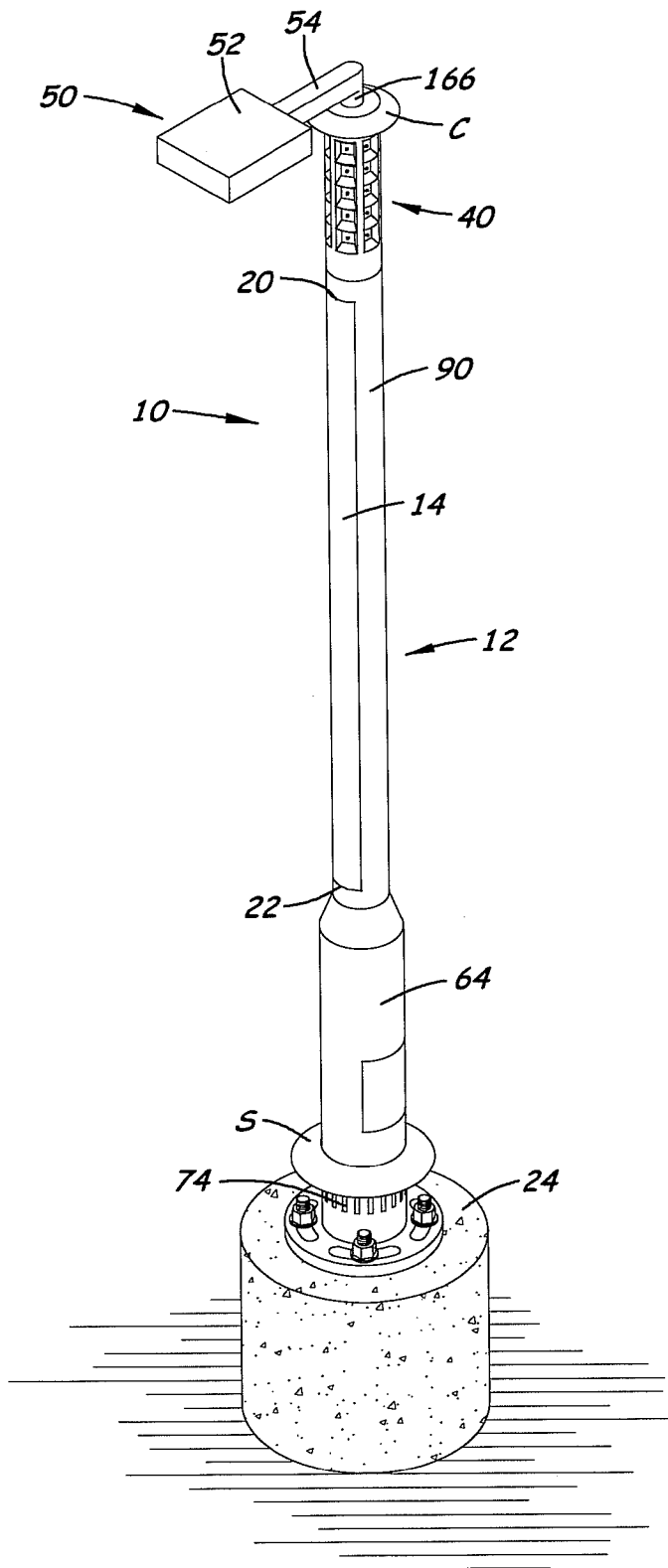

Fig. 1

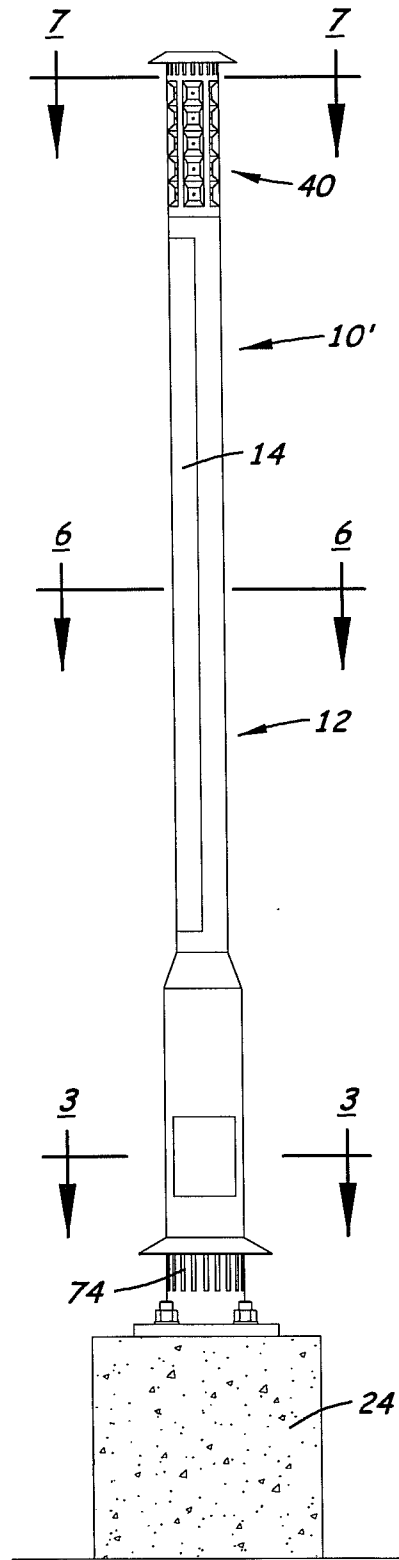

Fig. 2

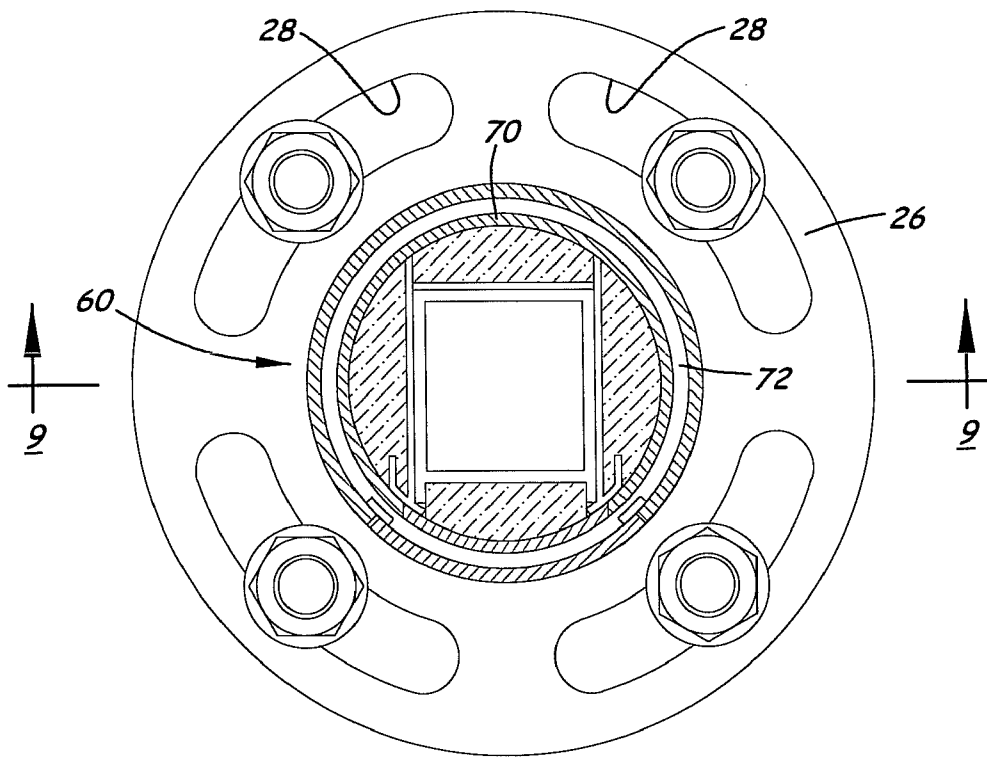

Fig. 3

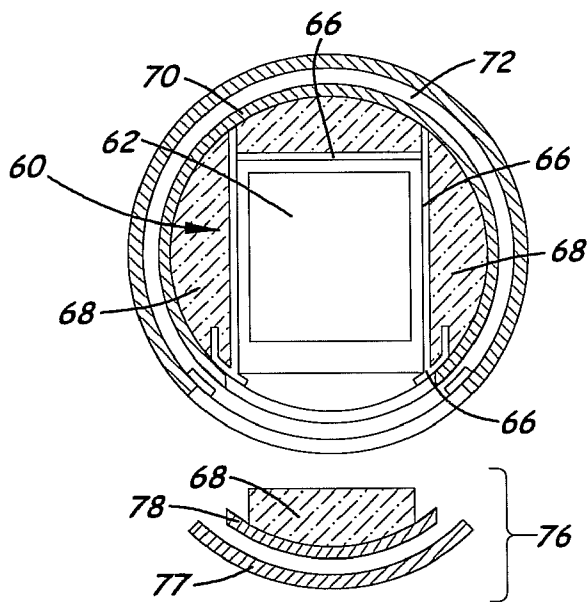

Fig. 4

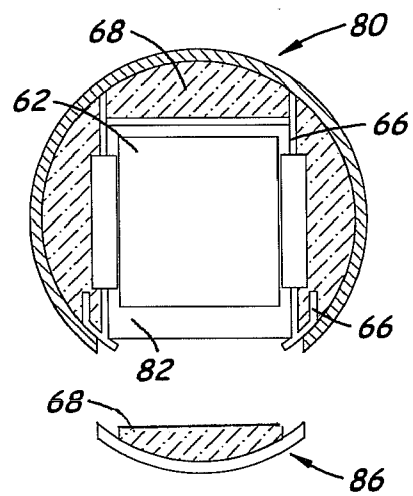

Fig. 5

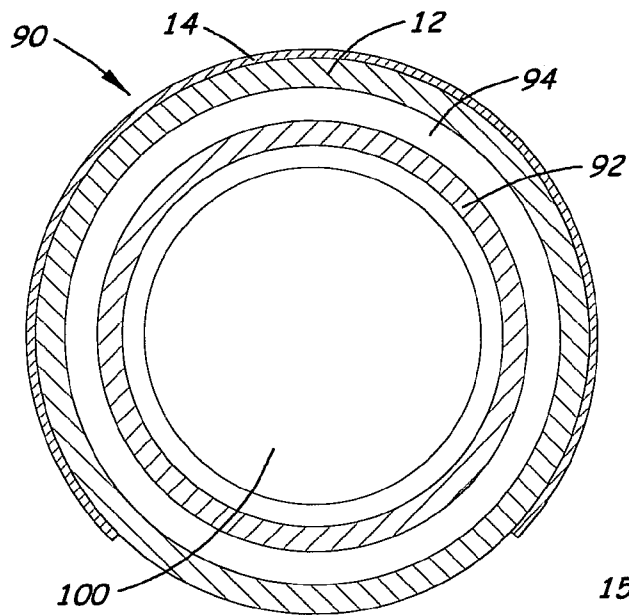

Fig. 6

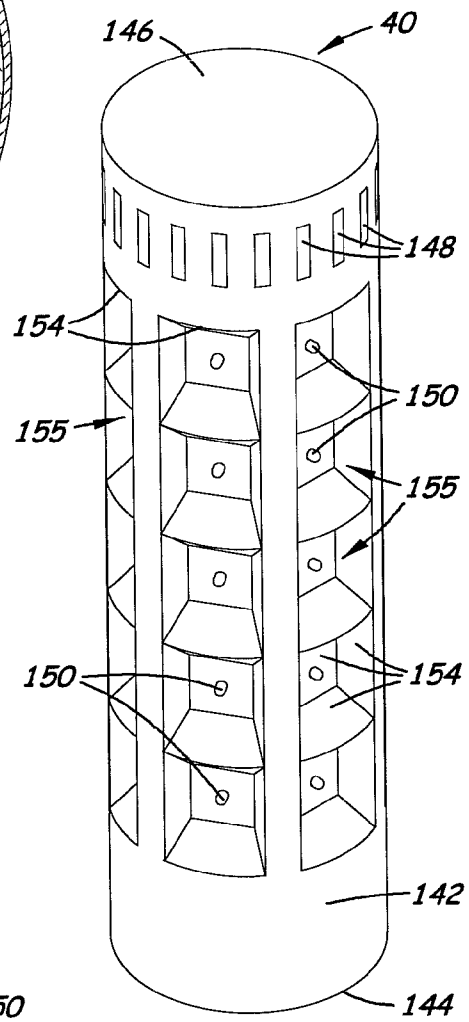

Fig. 8

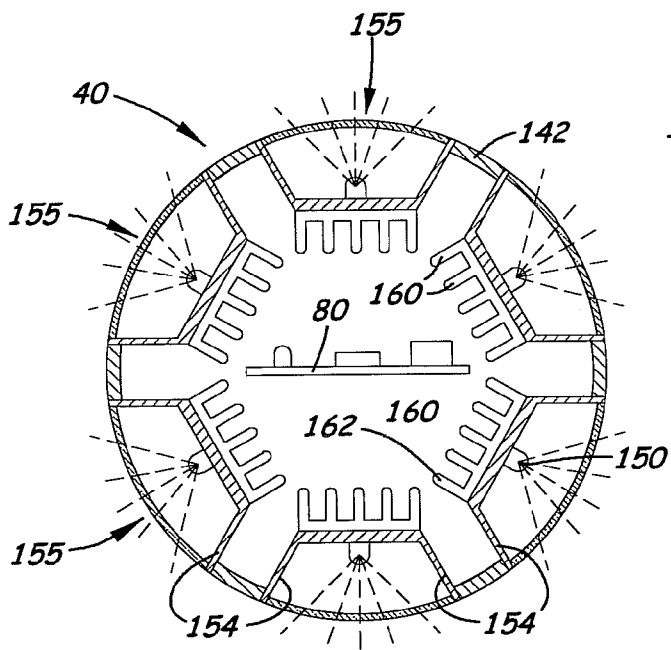

Fig. 7

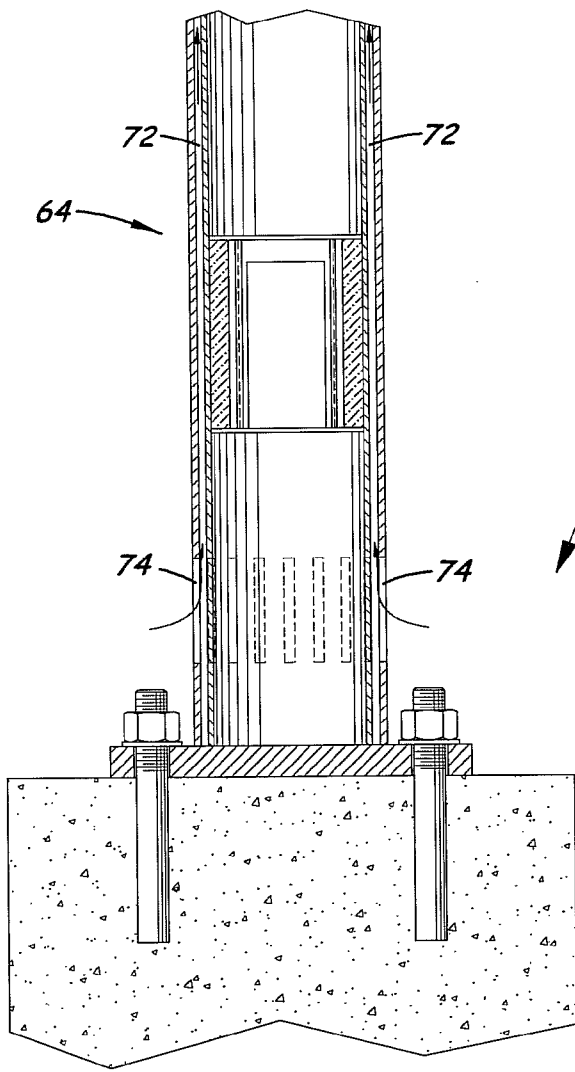

Fig. 9

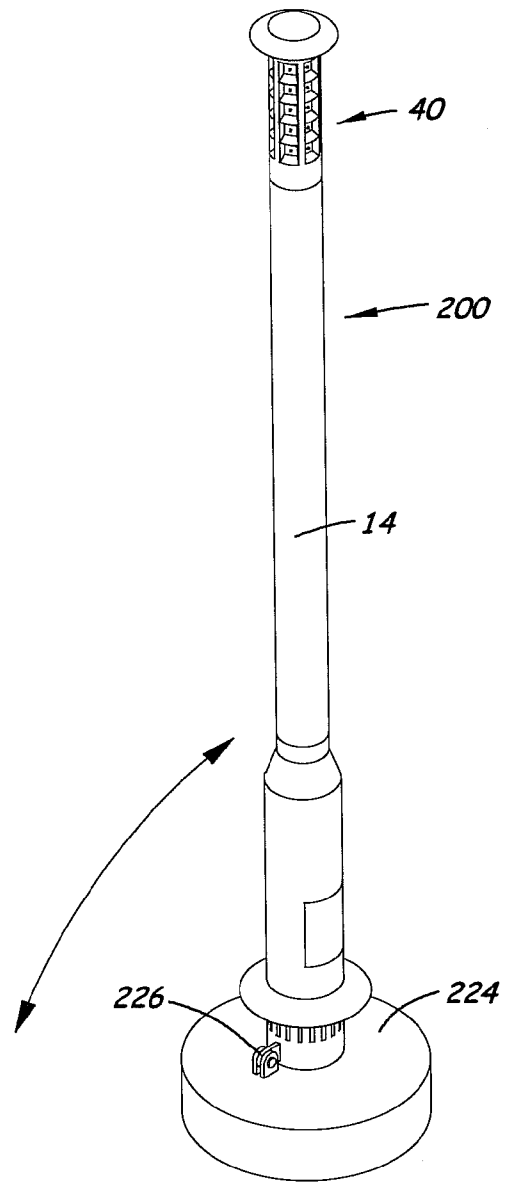

Fig. 10

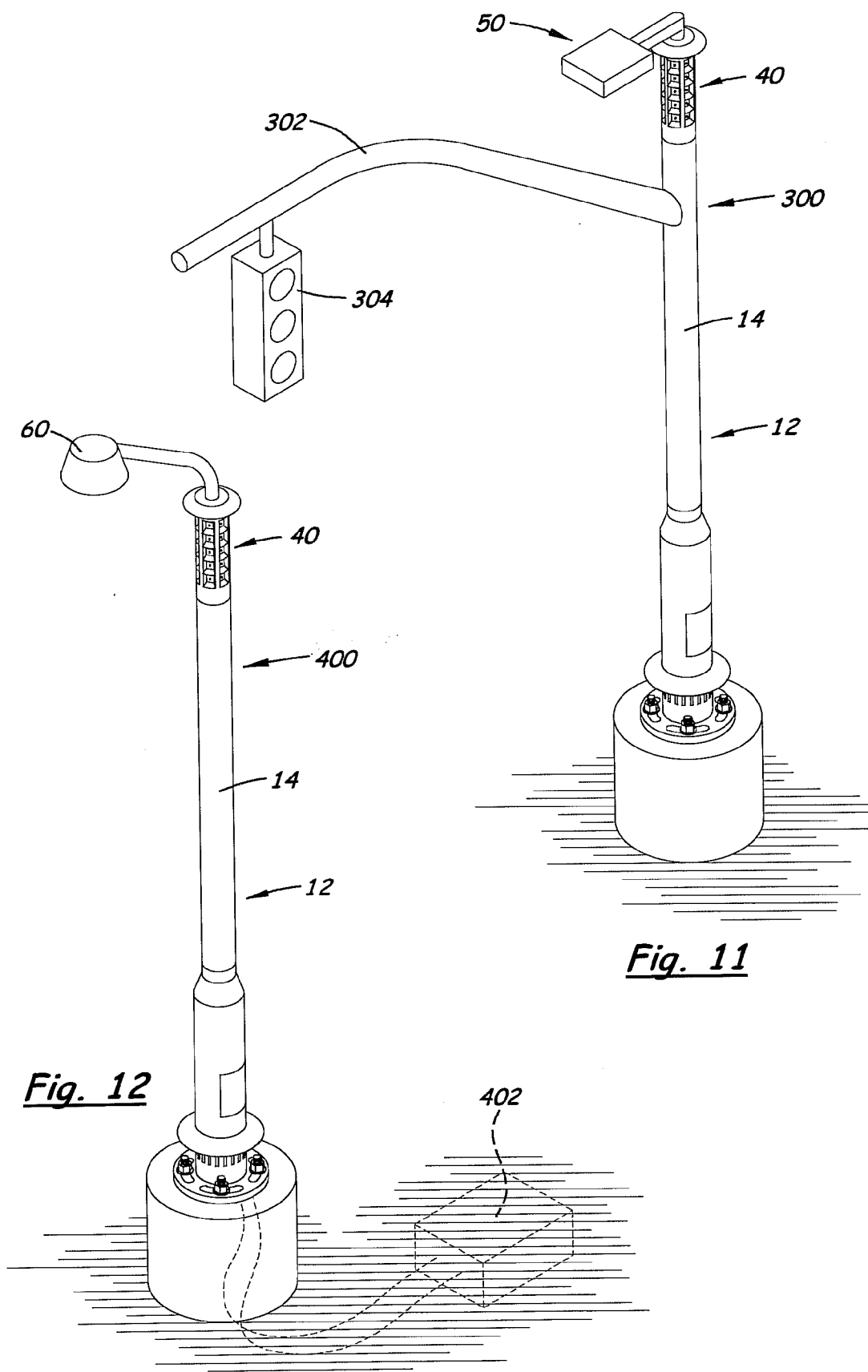

Fig. 11

Fig. 12

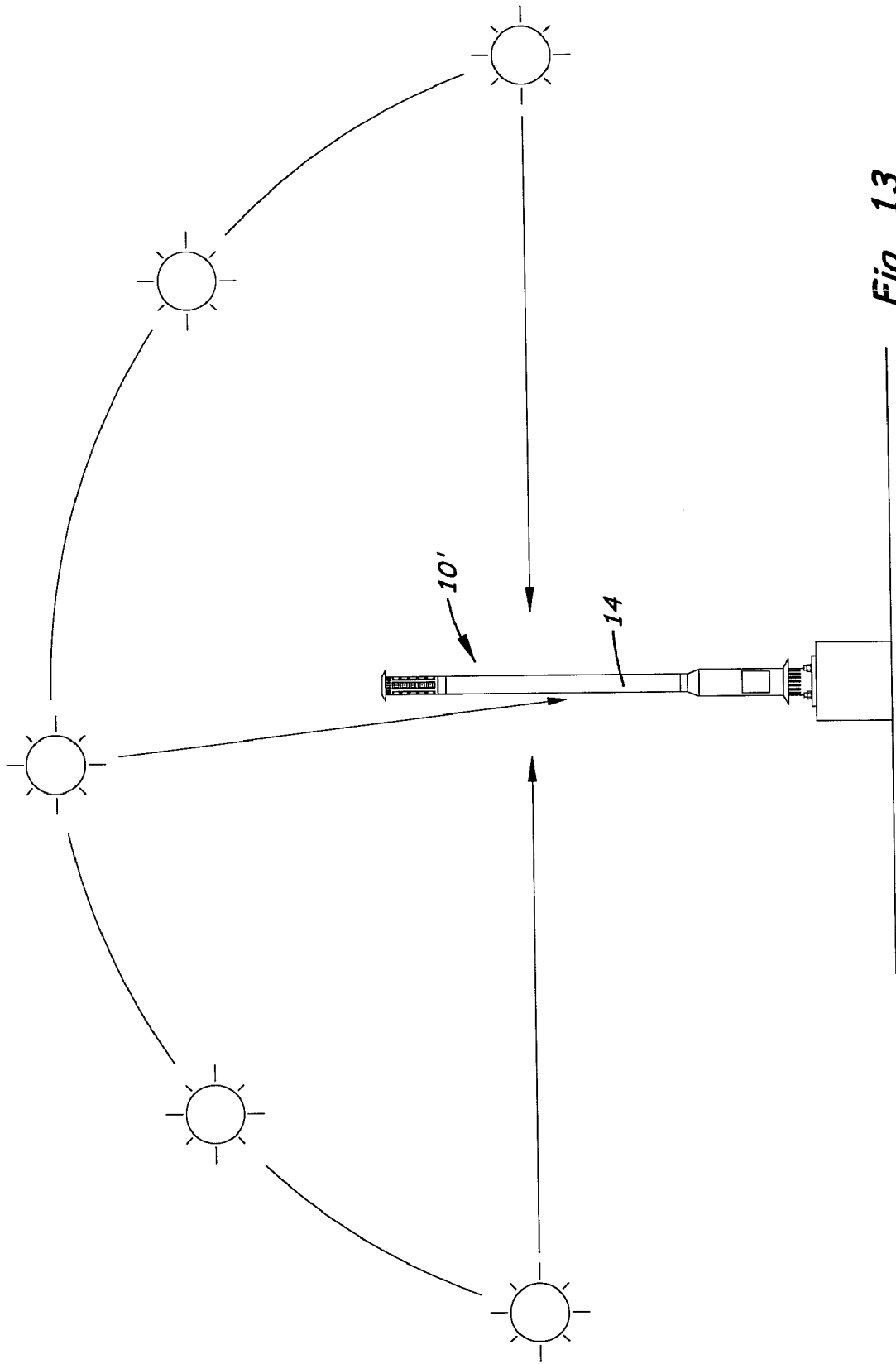

Fig. 13

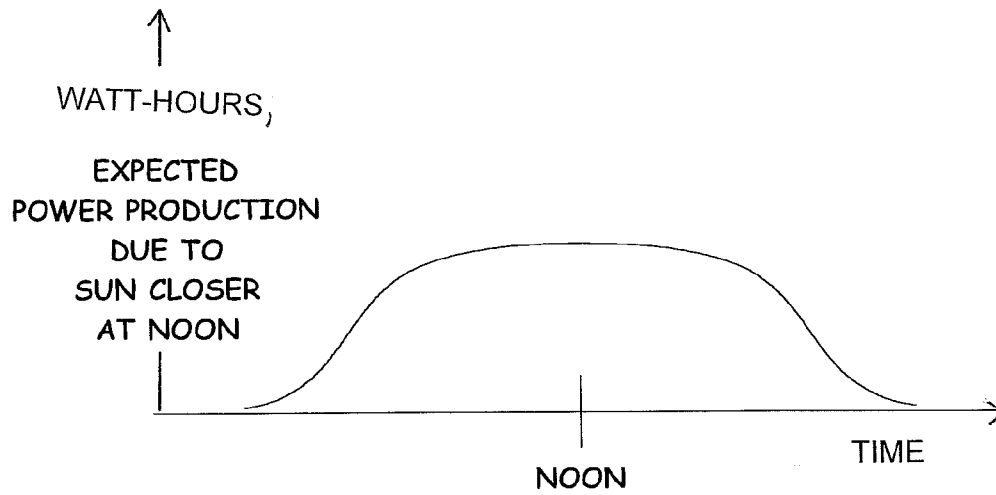

Fig. 14

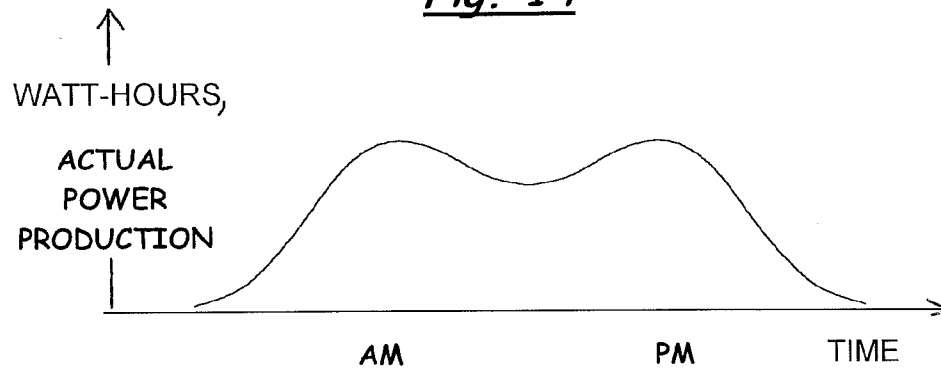

Fig. 15

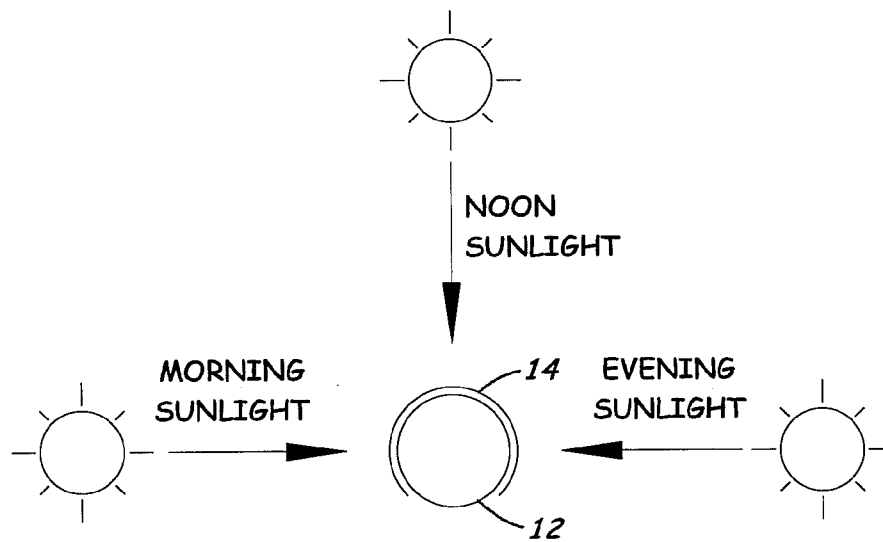

Fig. 16

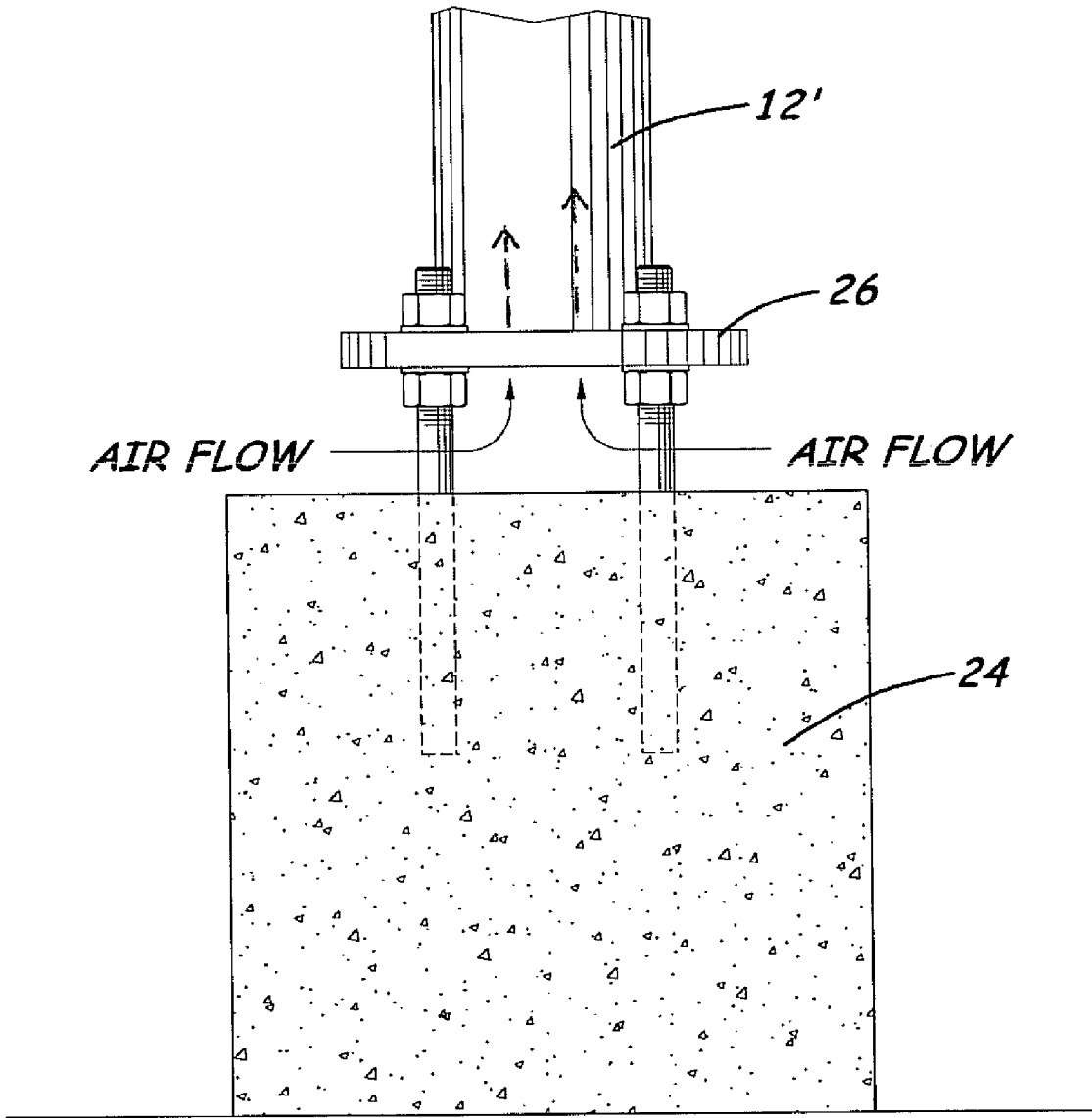
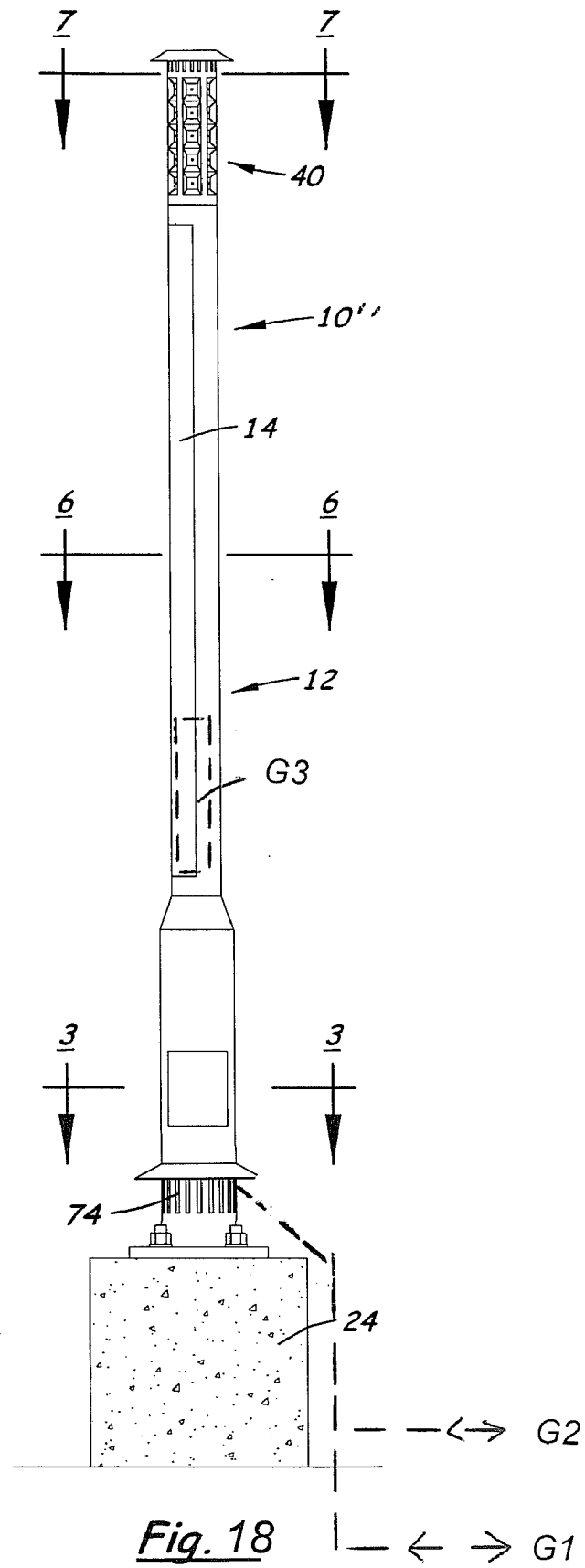

Fig. 17



SOLAR-POWERED LIGHT POLE AND LED LIGHT FIXTURE

[0001]

BACKGROUND OF THE INVENTION

[0002] 1. Field of the Invention

[0003] This invention relates to solar-powered outdoor lighting. More specifically, the invention relates to pole-mounted lighting that is powered by solar energy by means of a photovoltaic panel on the outside surface of the pole and batteries or other storage devices. The invented outdoor lighting has a structure, shape, and profile that look much like conventional street lights, for matching pre-existing street lights and/or accommodating local or governmental aesthetic preferences.

[0004] 2. Related Art

[0005] Solar-powered street lights and light fixtures have been developed in the past. For example, the patent literature includes: Robbins (U.S. Pat. No. 5,149,188, issued Sep. 22, 1992); Yoshida (U.S. Pat. No. 6,060,658, issued May 9, 2000); Wang (U.S. Pat. No. 6,784,357, issued Aug. 31, 2004); and Doppelt (U.S. Pat. D517,233, issued Mar. 14, 2006). Also, solar-powered street lights have been available commercially and/or tested publicly that include flat panel(s) of solar cells in a rack or frame, said flat panels typically being supported above the light pole. Such flat panels of solar cells are typically visually distracting and/or aesthetically unappealing, as they are a large protuberance from the street light and/or have the appearance of a large platform supported atop the street light. Yoshida discloses a street light with multiple flat panels of solar cells provided vertically on more than one side of a street light pole. Yoshida and the other prior art known to the inventor, however, do not address or solve many of the issues that the present inventor has found to be important in providing an efficient, economical, temperature-versatile, long-life, and aesthetically-pleasing solar-powered outdoor light system.

[0006] Therefore, there is still a need for an outdoor lighting system that is highly efficient in collecting and storing energy from the suns rays, and in using said energy over several nights to light a surrounding area even through inclement, overcast periods of time. The present invention meets these needs. Preferred embodiments utilize a cooling system that may greatly increase battery life and efficiency of the entire system. Preferred embodiments also utilize an efficient, versatile LED light fixture that may be used for all or nearly all street light styles without the need to separately engineer LED fixtures for each lamp/fixture style desired by the public, government, or neighborhood. Preferred embodiments have a visually-integrated appearance, preferably without flat panels of solar cells, and preferably with minimal or no unaesthetic protuberances and exposed equipment.

SUMMARY OF THE INVENTION

[0007] The present invention comprises solar-powered outdoor lighting that utilizes a photovoltaic panel(s), preferably amorphous photovoltaic laminate (PVL), and light-emitting diodes (LEDs) to produce light, over a several-night period even during inclement, cloudy, or overcast weather condi-

tions. In one embodiment, the invention comprises a light pole having a vertical portion covered by a flexible photovoltaic panel for being contacted by sunlight, and an LED light fixture powered by said photovoltaic panel via a battery or other energy storage device. The preferred flexible panel is a sheet of amorphous thin-film photovoltaic material(s) surrounding a significant portion of the circumference of the pole at least in one region along the length of the pole, and, preferably along the majority of the length of the pole. The light pole is specially-adapted for cooling of the photovoltaic panel, the batteries contained within the pole, if any, and the preferred LED light fixture. Said cooling is important for achieving the high efficiencies of power production and storage, over long equipment lives, as exhibiting by the preferred embodiments

[0008] The preferred light pole according to the invention is similar in exterior appearance to conventional light poles, in that the pole profile is generally smooth and of generally the same or similar diameter all the way along the length of the pole. The photovoltaic panel fits snugly against the pole outer surface and requires no brackets, racks or other protruding structure. The preferred LED fixture is at or near the top of the pole, is generally a vertical cylinder of the same or similar diameter as the pole, and may be convectively cooled by air flow up through the pole. The preferred LED fixture eliminates the need for the difficult engineering task of adapting the many common styles of outdoor light fixtures to use LEDs. Further, because the preferred battery system is concealed either inside the pole, inside a base holding the pole, or buried below the grade level of the ground or street, there is no need for a large box or protruding battery structure on or near the pole.

[0009] In the event that the purchaser or public wish the lighting system to match or be reminiscent of previously-installed or other conventional street lights, a conventional-looking lighting fixture may be provided in addition to the preferred LED fixture. Said conventional-looking lighting fixture may extend horizontally or from atop the pole, and may be purely decorative, or may have a minimal or token light-emitting device therein. Such a decorative light fixture may more easily meet with approval from the public and/or may blend in with traditional street lights that remain in an area. By using a combination of the LED fixture and a decorative fixture, the single LED light-producing section may be engineered and installed, while preserving various aesthetic options for the city, county, or neighborhood and/or while allowing the new solar-powered lights to “blend in” with the street lights already in place. Further, the decorative light fixtures may be light-weight and designed to break-away in high winds or storms, thus minimizing the damage to the pole, surrounding property, and/or people.

[0010] The preferred LED light fixture comprises arrays of LED's that emit light from at least three and preferably four generally vertical sides of the fixture. The LED light fixture may emit light out in patterns extending 180 degrees-360 degrees around the fixture, for example. The LED fixture comprises heat exchange or other cooling means in order to lower the temperature of the LEDs and the associated equipment.

[0011] In another embodiment, an outdoor light pole, having the features described above, is provided on, and hinged to, a portable base. In such an embodiment, the battery system may be located in, and provide additional weight for, the base.

[0012] In some embodiments, the solar-powered outdoor lighting system is connected to the utility grid, so that the photovoltaic panel may provide energy to the grid during peak-demand daylight hours, and so that, if needed or desired, low cost night-time electricity may be provided by the grid to the outdoor lighting system. Preferably, even in such embodiments tied to the grid, batteries or other storage devices are provided that may also be charged during the daylight hours, for providing power to the lighting system during the night hours, and/or providing power to the lighting system in the event of a grid failure or natural catastrophe that interrupts grid power supply.

[0013] In the preferred embodiments, venting and/or air channels are provided in the pole to allow cooling by natural convection air flow through the pole and the light fixture. Optionally, heating equipment may be provided in one or areas of the pole to protect equipment and/or enhance operation during extreme cold.

[0014] In other embodiments, the invention comprises the LED fixture without the street light pole, wherein the fixture may be connected to various other poles or stands, supports, fences and buildings. The LED fixture may be effective and aesthetically pleasing for various patio, driveway, entryway, commercial buildings, and/or other outdoor supports and structures, for efficient and long-lived light production.

[0015] In other embodiments, the invention comprises the solar-powered pole only, wherein power supplied by the photovoltaic panel on the pole may be provided to various types of apparatus, including LED lights, incandescent lights, and equipment other than lights.

BRIEF DESCRIPTION OF THE DRAWINGS

[0016] FIG. 1 is a front perspective view of one embodiment of a light pole system according to the invention, the light pole being anchored to a concrete base.

[0017] FIG. 2 is a side view of the embodiment in FIG. 1, with the decorative light fixture removed.

[0018] FIG. 3 is top, cross-sectional view of the light pole of FIGS. 1 and 2, viewed along the line 3-3 in FIG. 2, and illustrating to best advantage one embodiment of an adjustable connection between the light pole and the concrete base, and one embodiment of a battery system provided in the lower section of the pole.

[0019] FIG. 4 is a top, cross-sectional view of the battery compartment of FIG. 4, shown with pole and sleeve access doors removed for access to the batteries.

[0020] FIG. 5 is a top, cross-sectional view of an alternative battery compartment, without a sleeve and with a single access door through a side of the pole.

[0021] FIG. 6 is a top, cross-sectional view of a middle section of the pole of FIGS. 1 and 2, illustrating the preferred flexible amorphous photovoltaic panel applied to the outside of the pole, and a sleeve system for cooling the photovoltaic panel and allowing air flow to continue up to the LED light fixture.

[0022] FIG. 7 is a top, cross-sectional view of the LED fixture of the embodiment of FIGS. 1 and 2.

[0023] FIG. 8 is a side, perspective view of the LED Fixture of FIGS. 1, 2, and 7.

[0024] FIG. 9 is a partial, cross-sectional side view of the bottom section of the light pole containing a cooling sleeve and one or more batteries, illustrating natural air flow up through the sleeve. The rain skirt has been removed from this embodiment.

[0025] FIG. 10 is a side perspective view of an alternative embodiment of the invention, which comprises a portable light pole with LED fixture, said light pole being hinged to a portable base and so being pivotal from a generally horizontal position for transport or storage to a vertical position for use.

[0026] FIG. 11 is a side, perspective view of another embodiment comprising a decorative light fixture at the top of the pole plus an arm and traffic light extending from the pole.

[0027] FIG. 12 is a side, perspective view of another embodiment of the invented light pole system for use by a highway, wherein the battery system is buried in the ground instead of being contained inside the pole or inside the base, and wherein the pole may be a break-away pole, both features being for improved safety in the event of a vehicle hitting the pole.

[0028] FIG. 13 is a schematic illustration of sunlight hitting the preferred vertical photovoltaic panel adhered to the light pole, wherein morning and evening light hit the sheet at close to perpendicular to the sheet surface and the noon sunlight hits the sheet surface at an acute angle.

[0029] FIG. 14 illustrates the common conception of power production (for example, watt-hours) vs. time that is expected to be produced from a light-active device over a day.

[0030] FIG. 15 illustrates the actual power produced (for example, watt-hours) vs. time, by embodiments of the invention, wherein power production from the morning and evening sun is higher than expected. The curve illustrates a power production increase from early morning until mid or late morning, and then a dip in production due to the sharp incident angle of sunlight around noon when the sun rays hit the pole at sharp angles to the photovoltaic panel.

[0031] FIG. 16 schematically illustrates that the preferred photovoltaic panel is provided around most of the circumference of the pole, so that said panel is available and catches the sun's rays during the entire day.

[0032] FIG. 17 is a partial detail view of an alternative, especially-preferred lower pole vent, wherein air is taken in between the pole flange and the base, through spaced between bolts that secure and raise the pole slightly above the base.

[0033] FIG. 18 is a perspective view of an alternative solar-powered light system including a connection (shown schematically) to a utility grid.

DESCRIPTION OF THE PREFERRED EMBODIMENTS

[0034] Referring to the Figures, there are shown several, but not the only, embodiments of the invented lighting system. FIG. 1 portrays one embodiment of a solar-powered street light 10, comprising a pole 12 with a panel 14 of thin-film photovoltaic material attached thereto. The panel 14 is preferably selected from commercially-available amorphous silicon (non-crystalline) photovoltaic materials that produce electrical energy when exposed to sunlight. One source of material for the panel 14 is Uni-Solar (United Solar Ovonic), which flexible, non-framed laminates that may be used in embodiments of the invention, under the name of UNI-SOLAR® "solar laminates" or "photovoltaic laminates."

[0035] While currently-available flexible photovoltaic laminates, such as the UNI-SOLAR solar laminates are preferred, it is envisioned that thin-film light-active materials being developed, or to be developed in the future, may be used in embodiments of the invention, wherein said materials being developed or to be developed may be used in the place

of the panel **14** described herein. For example, it is envisioned that photovoltaic material may be applied directly to the pole **12** in the form of a liquid having components that later polymerize or “set Lip” on the pole and retain the photovoltaic material on said pole. Thus, the flexible photovoltaic panels described herein may be provided as a flexible sheet attached to the pole, or as other thin-film materials applied to the pole and taking the form of the pole, that is, preferably curving at least 225 degrees around the pole.

[0036] The panel **14** is a thin, flexible sheet that is preferably adhered to the pole by adhesive. The panel **14** may be a single, continuous sheet with “self-stick” adhesive on a rear surface, and that, upon peeling off of a protective backing, may be directly applied to the pole. The integral adhesive makes attachment of the panel **14** simple and inexpensive. No bracket, rack, covering, casing, or guard is needed over or around the panel, and this simplicity of attachment preserves the aesthetics of the preferred slim and smooth profile of the pole. Less-preferably, multiple, separate panels may be adhesively applied to the post **12** and operatively connected.

[0037] The panel **14** extends continuously around the pole along a significant amount of the circumference (preferably at least 225 degrees and more preferably about 270 degrees) of the pole in order to be directly exposed to sunlight all through the daylight hours. As illustrated in FIGS. **13-16**, this coverage of the pole will expose the panel **14** to the sun's rays generally from sunrise to sunset, in order to maximize solar-power generation. The panel **14** preferably covers $\frac{1}{2}$ - $\frac{3}{4}$ of the length of the pole, extending from its upper edge **20** at a location near the top of the pole to its lower edge **22** several feet above the base **24** supporting the pole. It is preferred that the lower edge **22** be high enough from the ground or street level that passers-by or vandals cannot easily reach the panel **14** to cut, pry off, or otherwise damage the panel.

[0038] Connection of the pole **12** to the base **24** may be done in various ways, each typically being adjustable so that, at the time of installation, the pole may be turned to orient the panel **14** optimally to catch sunlight through the day. The adjustable connection, shown in FIGS. **1** and **3** to best advantage, includes a pole base flange **26** having multiple, curved slots **28** through which bolts extend, so that the bolts may be tightened to secure the pole to the base **24** after the pole is rotated to the desired orientation. The connection of the decorative light fixture (**50**, discussed below), may also be adjustable, so that, given any orientation of the pole, the decorative light fixture may be secured/tightened to point in the desired direction, for example, over a street or sidewalk.

[0039] The main, or only, light-producing unit of the preferred street light **10** is a light-emitting diode (LED) fixture at or near the top of the pole **12**. The preferred LED fixture **40** has a cylindrical outer surface and is coaxial with, and of generally the same diameter as, the upper end of the pole **12**. This LED fixture, as will be discussed further below, may emit light out in a 360 degree pattern, or, may be adapted by LED and/or reflector placement and shape to emit various patterns of light as needed for a particular setting.

[0040] The decorative light fixture **50** is portrayed in FIG. **1** as a box-style fixture on a horizontal arm, but may be other fixtures. The decorative light fixture **50** comprises a housing **52** and connecting arm **54** that are the same or similar to conventional fixtures. The decorative light fixture **50**, however, has no internal or external workings to produce light, no bulb and no wiring, as the fixture **50** is merely a “token” or “fake” light fixture simulating the appearance that the public

is used to. The decorative light **50** may have a conventional lens that contributes to the fixture looking normal during the day. Alternative decorative light fixtures may be provided, for example, a “gas lamp” glass globe that extends up coaxially from the LED fixture **40**, or a curved-arm with conical housing **60** as shown in FIG. **12**.

[0041] The inclusion of a decorative fixture may make the overall appearance of the street light **10** more desirable for the public or the governmental/transportation agency installing and maintaining the street light **10**. This may make the overall appearance of the street light **10** match or complement pre-existing fixtures or the style or desires of a neighborhood. Having a decorative light fixture **50** may be reassuring and comforting to the public, as they will automatically recognize the street light **10** as a light for public safety, rather than worrying that the structure is an antenna or transmitter, surveillance structure, or some other undesirable structure in their neighborhood, for example.

[0042] Alternatively, the decorative light fixture **50** may be adapted to provide some light output, for example, a single LED or other minimal light source to further enhance the aesthetics of the street light **10**. Such a minimal light source will light the interior of the housing and/or the fixture lens, to prevent the decorative fixture from appearing to be burnt-out, and to suggest to passers-by that the fixture **50** is indeed providing light as is customary and comfortable for the public. While said decorative light fixture **50** may comprise said minimal light source, it is preferred that the LED light fixture provide at least 80 percent, and preferably at least 90 percent, of the light from the system **10**, **10'**.

[0043] FIG. **2** illustrates the light pole in use with the decorative, non-lighting or minimally-lighting fixture **50** removed, in which form the street light **10'** is fully functional for providing the desired amount of light for the street or neighborhood by means of the LED fixture **40**. This version of street light **10'** has, therefore, no significant protrusions from its elongated, vertical structure, and has a slim, sleek appearance that, over time, may become preferred for many settings.

[0044] FIG. **3** illustrates the adjustable connection of the pole **12** to the base **24**, and shows the internals, in cross-section, of the storage system **60** with batteries **62** stored in the lower section **64** of the pole and operatively connected to the panel **14**. The batteries **62** store the energy provided by the solar panel during the day or previous days, and power the LED fixture **40** during the night. The battery system is adapted to store enough energy to power, when fully charged, the LED fixture **40** for several nights with little or no additional charging and without any outside energy input. The battery system preferably stores enough energy to power the LED fixture for at least 5 nights and, more preferably, 5-9 nights equating to about 50-100 hours or more depending upon the number of hours in a night. Thus, the street light **10**, **10'** is capable of autonomously illuminating (that is, with only the energy provided by the stored energy from solar collection) the surroundings for several, and preferably at least 5 nights, even when the light **10**, **10'** is located in an overcast, inclement, hazy or smoggy location, all of which conditions will diminish the intensity of the daytime sun hitting the panel **14**. In other words, the large amount of energy stored in the batteries during days of clearer weather is sufficient to “carry the light through” cloudy and inclement weather for about a week, until improved sunlight conditions return. The amorphous thin-film panel **14** is more shade-tolerant than conven-

tional crystalline solar cells, and is therefore expected to be more efficient and effective than banks or racks of crystalline solar cells.

[0045] In alternative embodiments, the light **10**" (see FIG. **18**) may be tied to the utility grid, for example, for providing power to the grid during the day and preferably also charging batteries during the day, and then receiving less expensive power from the grid during the night and/or also receiving power from the batteries as a supplemental/backup power source. In FIG. **18**, connection to the grid is shown schematically as G1 (underground) or G2 (above-ground) and one of skill in the art will understand how to build, install, and manage said connections. Such a grid-tied embodiment that also has battery storage capability may provide the benefit of supplementing the grid during peak electricity-usage hours, while also being capable of being autonomous (independent of the grid) in the event of disaster or other grid outage. In such embodiments, an inverter and control and measurement systems (G3 in FIG. **18**) will be added, for example, inside the pole, to cooperate with the utility grid and measure and record the system's energy contribution to the grid.

[0046] Controllers are provided to manage charging of the batteries and delivery of energy to the lighting system and/or other components. Control of the operative connection between the batteries **62** and panel **14** and the operative connection between the batteries and the LED fixture **40** and other components may be done by electronics, circuitry, and/or semiconductors, for example, control board **80** shown in FIG. **7**. The controller(s) preferably continually monitor(s) battery voltage and temperature to determine battery health, to improve both battery performance and life. Said controller (s) preferably control the speed and the amount that the batteries are charged and discharged, which can significantly affect battery life. Combined with the preferred cooling system for managing battery temperature, the batteries of the preferred embodiments are expected to exhibit longer lives, and better performance, than prior art batteries installed in solar-powered light systems.

[0047] A first controller delivers a low-current (trickle) charge from the solar collector panel **14** to the batteries. This controller also preferably limits the maximum voltage to a voltage that will not damage or degrade the battery/batteries. A second controller draws current from the battery/batteries and delivers it to the LED fixture and other electric device(s) requiring power from the batteries. The minimum battery voltage is also protected by the controller to prevent excess battery drain. During prolonged periods of inclement weather and low daytime energy generation, the controller(s) may dim the lights during part or all of the night to reduce the amount of energy being consumed while still providing some lighting of the surroundings. The controller(s) may turn the light on based on a signal from a photocell and/or a motion sensor, and off with a timeclock, for example.

[0048] The controller system(s) may comprise computer logic, memory, timers, ambient light sensors, transmitters, receivers, and/or data recording and/or output means. Said controller systems may comprise only electronics and apparatus to operate the single light **10**, **10'** in which it resides, or may additionally comprise electronics and apparatus that communicate with a central control station and/or with other street lights. Said communication is preferably accomplished wirelessly, for example, by means of a "multiple-node" or "mesh" network via cell-phone radio or satellite communication. Such a network of multiple street lights ("multiple

poles") and a central control station may allow monitoring, and/or control of, the performance of individual lights and groups of lights, for example, the lights on a particular street or in a particular neighborhood or parking lot. Such performance monitoring and/or control may enhance public safety and improve maintenance and reduce the cost of said maintenance. A central control station may take the form of, or be supplemented by, a server accessible via an internet website, for example.

[0049] The entire system for storing and using energy preferably uses only direct current (DC). Benefits of this include that LED lights use DC energy; the DC system is low-voltage, easy to install and maintain, and does not require a licensed electrician; and energy is not lost in conversion from DC to AC.

[0050] The preferred batteries are sealed lead-acid AGM-type batteries or gel-cell batteries, nickel metal hydride batteries, or lithium batteries, for example. It is desirable to maintain the batteries **62** within a moderate temperature range, for example, 40-90 degrees F. as exposure of the batteries to temperatures outside that range will tend to degrade battery performance and life. Daily battery performance may be reduced by more than 50 percent by cold weather, and batteries may stop working entirely in very low temperatures. Further, high temperatures tend to also degrade battery performance and life.

[0051] In the preferred configuration shown in FIG. **4**, the batteries **62** are supported in a bracket(s) **66** and surrounded on multiple sides by insulation **68** for protecting the batteries from cold weather, preferably to help keep the batteries above about 40 degrees F. Further, said insulated batteries, and/or the bracket system supporting them, are connected to and contained inside a cooling sleeve **70** that is beneficial in hot weather, preferably to keep the batteries below about 90 degrees F. The cooling sleeve **70** is concentric with, and the same general shape as the wall of the pole **12**. The sleeve **70** is of smaller diameter compared to the pole, for example, 2-4 inches smaller diameter, forming an annular air flow space **72** inside the pole along the length of the lower section **64** of the pole. Air enters the intake vents, for example, slits **74** around the pole in FIGS. **1** and **2**, and flows up through the annular space **72** past the bracket(s) **66** and batteries **62** to cool said batteries **62**. Said vents **74**, and the open top of the flow space **72** that preferably communicates with the LED light fixture **40**, are examples of at least one lower pole vent and at least one upper pole vent adapted for ventilation of at least a portion of the pole by natural convection up through said at least one portion of the pole. Preferably, the flow space **72**, or alternative internal spaces for draft up the pole, communicates with the LED light fixture, but alternative ventilation systems may be independent from the LED light fixture. Referring to FIG. **17**, there is shown another, alternative lower pole vent. The lower pole vent of FIG. **17** is provided (instead of vents **74**) by providing spaces around the flange of the pole **12'** by virtue of the flange being spaced from the base **24** by a bolt system that may be used to level the flange (make the pole vertical) on a base on uneven ground. The bottom end of the pole **12'** has a bottom end opening (not shown) into which the air flows (instead of flowing into vents **74**), and said bottom end opening is in fluid communication with the annular space **72** or other interior axial spaces inside the pole for creating the ventilation draft described elsewhere in this disclosure.

[0052] In FIG. **5**, an alternative battery system **80** is shown, wherein no cooling sleeve is provided, but air may flow up

through the battery section through axial spaces **82** around the batteries **62**. Insulation **68** is preferably provided at and near the pole inner surface and extending most of the way to the batteries **62**, however, with the exception of the axial spaces **82** that provide channels for air flow up through the system **80**.

[0053] One may note that the designs shown in FIGS. **4** and **5** both have access doors systems **76**, **86** that allow insertion, maintenance, and removal of the batteries **62** from the lower section **64**. The access door system of FIG. **4** comprises both a door **77** in the pole and a door **78** in the sleeve **70**. The sleeve door **78** of FIG. **4** may be insulated, so that the batteries are surrounded circumferentially by insulation, or, in alternative embodiments the sleeve door **78** may be un-insulated or even eliminated. The access door system **86** of FIG. **5** comprises only a door in the pole, and is insulated, so that the batteries are surrounded circumferentially by insulation. Other bracket, insulation, and door configurations may be effective, as will be understood by one of skill in the art after reading this disclosure.

[0054] FIG. **6** illustrates the internal structure of the middle section **90** of the pole **12**, wherein the flexible panel **14** is wrapped and adhered to the pole outer surface. It should be noted that the preferred pole is a hollow, straight (or right) cylinder, and the preferred panel **14** is applied continuously around at least 225 degrees of the pole, so that sunlight "collection" is maximized. However, other pole shapes may be effective if the corners are rounded to allow the panel **14** to bend gently around said corners. For example, a square, rectangular, or polygonal pole, with rounded corners, may be effective, with the panel **14** still being provided in a single panel, and not needing to be held in brackets or frames on the various flat sides of the poles.

[0055] Inside the middle section **90** of the pole **12** is an axially-extending sleeve **92**, which creates an annular space **94** that extends through the entire middle section **90**. This annular space **94** fluidly communicates with the annular air flow space **72**, or other air flow spaces **82** of the lower section **64**, so that air vents from the lower section **64** through space **94** of the middle section **90** and to the LED fixture **40**, as further described below. Ventilation by air flow up through the middle section **90** of the pole keeps the inner surface of the panel **14** cooler than the outer surface that is "collecting" the sun light. This may be important for efficient operation of the solar panel **14**, to maintain a temperature gradient between the higher temperature outer surface and the cooler inner surface of the panel. Thus, it is not desirable to have insulation between the panel **14** and the pole **12**. The pole middle section **90** may be made without a sleeve **92**, in which the hollow interior of the pole might serve in place of space **94** as the air vent chimney in fluid communication with spaces **72** or **82** and the LED fixture.

[0056] The middle section **90** may house long-term energy storage **100** comprising capacitors, fuel cells and/or a hydrogen storage tank, for example. Capacitors would have the advantage that they would not be as affected by heat and cold as are batteries. Typically, capacitors would have longer lives than batteries, for example, up to about 20 years, compared to 2-5 years for batteries. Fuel cells could be used for applications that require longer autonomy than 5 days. The fuel cell and hydrogen storage tank could be integrated into the middle section **90** or lower section **64** of the pole, or into the base or an underground container. Venting similar to that required for the battery system would be required for off-gassing.

[0057] FIGS. **7** and **8** portray transverse cross-section, and side perspective, views, respectively, of the preferred LED fixture **40** positioned above the middle section **90** of the pole. The fixture is preferably cylindrical and longer axially than it is in diameter. The fixture **40** is preferably the same diameter as the pole middle section, and comprises preferably a constant or nearly-constant-diameter housing **142**. The housing **142** is substantially hollow with an open bottom end **144** in fluid communication with the middle section **90** and a closed upper end **146**. Vents **148** are provided near the upper end **146** to allow air that flows up through the pole **12** to pass through the fixture **40** and then exit at or near the top of the fixture. Open bottom end **144** and vents **148** may be considered examples of a lower vent and an upper vent adapted for ventilation of said light fixture by natural convection up through the light fixture. Other venting systems comprising at least one lower vent and at least one upper vent may be used, including, but not necessary limited to, systems that utilize upwards draft from/through at least portions of the pole to create/enhance ventilation of the LED light fixture. There also may be ventilation systems for the LED light fixture that are independent from pole ventilation.

[0058] Compared to other light sources, LEDs are smaller, more efficient, longer-lasting, and less expensive. LEDs use less energy than other light sources to provide the necessary lighting desired for a street light. LED may last up to 100,000 hours, or up to 10 times longer than other lighting sources, which makes LEDs last the life of the pole and the entire light system in general, especially when said LEDs are housing and cooled by the apparatus of the preferred embodiments.

[0059] Multiple LED lights **150** are arranged around the entire, or at least a significant portion of the, circumference of the fixture **40**. LED's are arranged in multiple vertical column units **155**, and said column units **155** are spaced around the circumference of the fixture **40** to point LED light out from the fixture 360 degrees around the fixture. In alternative embodiments, LED's may be provided around only part of the circumference of the fixture, for example, only around 180 degrees of the fixture to shine light generally forward and to the sides, but not toward the back. Six of the LED column units **155** are provided, each with five LEDs, but more or fewer units and LEDs may be effective. Reflectors **154** are provided on some or all sides of each LED and may be positioned and slanted to reflect light outward and preferably slightly downward as needed for a particular environment. The preferred arrangement of LEDs results in their being, in effect, columns and rows of LEDs.

[0060] At the back of each LED column unit **155** are located cooling fins **160**, protruding into the hollow interior space **162** of the housing **142** for exposure to air flowing upward from the middle section. Heat exchange from the fins and adjacent equipment to the flowing air cools each unit **155**, to remove much of the heat produced from the LED's. This heat exchange is desired to keep the LED's in the range of about 20-80 degrees, F. and, more preferably, in the range of 30-80 degrees F. LED performance and life are typically optimal when operated at approximately 30 degrees F., but a range of operation temperature (for example, 20-80 degrees F.) may be tolerated due to the inherent long lives of LEDs.

[0061] In the center of the fixture in FIG. **7**, one may see an example control board **80**, as discussed previously. Optionally, other equipment may be provided inside the fixture **40**, extending through to or on the outside of the fixture **40**, or in/on stem **166** or the rain cap **C** at the top of the fixture **40**.

Such equipment may include, for example, a camera and/or recorder for a security system, wireless network radio, antenna, motion sensor, and/or photocell. If provided on the outside, it is desirable to have such equipment consistent with the contour/shape of the fixture, for example, to be flush with, or to protrude only slightly from, the housing **142** outer surface. The control boards **80** and other equipment, if any, located inside the fixture **40** may be cooled by the upward-flowing air inside the fixture, in some embodiments, or, in other embodiments, may need to be insulated from their surroundings, depending on the heat balance in the LED fixture.

[0062] FIG. **9** portrays air being pulled into the lower section of the pole through slits **74** and continuing to flow up past the batteries and up through the pole, by natural convection. As provided by the structure of the pole and pole internals discussed above, the entire pole **12** will preferably be ventilated and designed to create an upward draft of air through the pole **12**. This air flow cools the battery section and the LEDs, for improved operation and greater efficiency. The air flow may cool the circuit board and any other equipment that may be provided in LED fixture, depending on the heat balance in the fixture, or said circuit board and other equipment may need to be insulated to keep the LEDs from heating them beyond desirable temperatures. While other solar-powered outdoor lights have been proposed, none to the inventor's knowledge have a cooling feature, and the inventor believes that the preferred embodiments will exhibit increased efficiency and long-life, due to the special combination of LEDs and cooling for batteries and LEDs. Optionally, heating equipment may be provided in one or areas of the pole to protect equipment and/or enhance operation during extreme cold. Cable or film heating means may be effective, and may be controlled by a thermal sensor and controller.

[0063] FIG. **10** portrays an alternative embodiment of the invention, which is a portable, pivotal outdoor light **200**. Light **200** comprises a pole with attached flexible panel **14** of amorphous thin-film photovoltaic material, LED fixture **40** at the top of the pole, and a heavy but portable base **224** that is neither connected to, nor buried in, the ground. The pole is hinged at **226** to the base **224**, for tilt-up installation at the use site. A lock (not shown) may secure the pole in the upending position until it is desired to remove and move the portable light **200** to storage or another location. Batteries may be provided in the portable base **224**.

[0064] FIG. **11** portrays an alternative embodiment **300** that includes a traffic light as well as a street light. The pole **12**, panel **14**, base **24**, LED fixture **40**, and decorative fixture **50** are the same or similar to those described above for the embodiment in FIGS. **1** and **2**. An arm **302** extends from the middle section of the pole, to a position over a street intersection, for example. A traffic light **304** hangs from the arm **302**, and is powered by the solar-powered system already described for the other embodiments. A control board and/or other apparatus and electronics will be provided to control the traffic light, in accordance with programs and instructions either programmed into the circuitry/memory of the embodiment **300** and/or Received from a control network and/or central control station.

[0065] FIG. **12** portrays a break-away, road-side outdoor light **400** embodiment, which has its battery system **402** buried in a vault in the ground rather than being in the lower section of the pole. The electrical connection between the batteries and the panel, the batteries and the LED fixture

extend underground. The rest of the light **400** is the same or similar as the embodiment in FIGS. **1** and **2**, except that the lower section does not contain batteries, and the decorative light is a different one of many possible styles. The lower section of the pole may have a sleeve for encouraging draft and air flow up to the LED fixture, but does not need to contain brackets for batteries. An access door may be provided, for example, to check on or maintain wiring or connections that may be reachable from the lower section. Adaptations, such as break-away bolts, are provided to allow the pole to break-away when hit by a vehicle, as is required for many highway lights. Having the battery system buried in the ground enhances safety because vehicles will not crash into the full mass of the pole plus base plus battery system. Alternatively, batteries could be located in a buried base, to which the pole may be bolted. The pole may be steel or aluminum, and may have rust resistant coatings applied for extending underground.

[0066] FIGS. **13-16**, as discussed above in the Summary of the Invention, illustrate the improved efficiency and effectiveness of the preferred embodiments of the invention. Sunlight hits the flexible amorphous panel **14** from all directions on its path "across the sky." The preferred continuous panel around at least 225 degrees of the pole circumference and along a substantial amount of the length of the pole, provides a large target that the sunlight hits "straight on" as much as is possible. The preferred cylindrical shape of the pole, and, hence, of the panel, provides a curved target that catches light from dawn to dusk.

[0067] The preferred outdoor light embodiments are what may be called "visually integrated," as they contain a great amount of operational capability inside and on a sleek, slim, and generally conventional-looking pole and installation. The preferred outdoor light embodiments do not include any flat-panel or framed solar cells. The pole has few if any protrusions, except for the optional rain shirt **S** which may be designed in many non-obtrusive ways, and an optional rain cap **C** that also may be designed in non-obtrusive ways. In embodiments having a decorative light fixture, said decorative light fixture may be considered a protrusion, but one that is expected and conventional-appearing. Most or all of the pole and its associated equipment, except for the decorative light, preferably varies only about 20 or less percent from the constant or substantially-constant diameter of the main (middle) section of the pole.

[0068] Particularly, the attachment of the preferred flexible amorphous light-active panel, or light-active materials of the future, is done simply and without racks, brackets, frames, and other complex or protruding material. Thus, the panel appears to simply be the side of the pole, for example, a painted or coated section of the pole wall. The preferred pole is a straight cylinder (with a constant diameter all along the middle section of the pole) that may be painted a dark color like black to match or blend with the dark color of the panel. The panel is not an ugly or strange-looking structure that would irritate the public, customers, or property owners who desire an aesthetically pleasing lighting system, and the panel does not have a high-tech appearance that might attract vandals or pranksters.

[0069] It should be noted that, while the preferred embodiments are outdoor lighting systems, that some embodiments of the invention may comprise the preferred LED fixture by itself and/or the preferred LED fixture in use with supports and equipment other than those shown herein. Also, some

embodiments of the invention may comprise the preferred solar-powered pole by itself and/or connected to and powering equipment not comprising any light source, powering non-LED lights, and/or powering equipment other than is shown herein.

[0070] Although this invention has been described above with reference to particular means, materials and embodiments, it is to be understood that the invention is not limited to these disclosed particulars, but extends instead to all equivalents within the broad scope of the following claims.

1. A light comprising:
 - a pole having a cylindrical section with an outer surface having a circumference;
 - a flexible panel of amorphous photovoltaic material adhesively connected to said outer surface so that the flexible panel curves at least 225 degrees around the cylindrical section;
 - a light fixture comprising a plurality of light-emitting-diodes (LEDs), wherein the light fixture extends from an upper region of said pole; and
 - an energy storage device operatively connected to said flexible panel so that, when sunlight hits said flexible panel, resulting electrical energy is stored in said storage device; and
 wherein said light fixture comprises at least one lower vent and at least one upper vent adapted for ventilation of said light fixture by natural convection up through the light fixture.
2. A light as in claim 1, wherein said pole comprises an internal space and at least one lower pole vent and at least one upper pole vent adapted for ventilation of at least a portion of the pole by natural convection up through said at least portion of the pole.
3. A light as in claim 2, further comprising at least one battery contained within said at least a portion of the pole, so that said at least one battery is cooled by said ventilation of said at least one portion of the pole.
4. A light as in claim 1, wherein said light fixture is a generally cylindrical fixture connected to a top end of the pole and wherein the light fixture has central axis that is coaxial with the pole and a circumference.
5. A light as in claim 4, wherein said light fixture comprises columns of LEDs arranged around at least 180 degrees of the circumference of the light fixture.
6. A light as in claim 4, wherein said light fixture comprises columns of LEDs arranged around 360 degrees of the circumference of the light fixture.
7. A light as in claim 4, further comprising, in addition to said cylindrical light fixture, a decorative light fixture that comprises no light source.
8. A light as in claim 4, further comprising, in addition to said cylindrical light fixture, a decorative light fixture that comprises only a single LED.
9. A light as in claim 7, wherein said decorative light fixture extends generally horizontally from the pole to extend over a street.
10. A light as in claim 3, wherein said at least one battery stores energy from said flexible panel sufficient to power said light fixture for at least 50 hours.
11. A light as in claim 10, further comprising a connection to a utility power grid to provide electricity to said power grid during daylight hours.
12. An outdoor light comprising:
 - a pole having an outer surface;

- a flexible panel of amorphous photovoltaic material adhesively connected to said outer surface;
 - a light fixture comprising a plurality of light-emitting-diodes (LEDs), wherein the light fixture extends from an upper region of said pole; and
 - an energy storage device operatively connected to said flexible panel so that, when sunlight hits said flexible panel, resulting electrical energy is stored in said storage device, wherein said energy storage device is located inside the pole; and
- wherein said pole comprises at least one lower pole vent, at least one upper pole vent, and an interior air flow space in fluid communication with said at least one lower pole vent and said at least one upper pole vent, so that a draft is created up through said interior air flow space to cool the pole.

13. A light as in claim 12, wherein said light fixture comprises at least one lower vent in fluid communication with the interior air flow space of the pole, at least one upper vent, and an internal space in fluid communication with said at least one lower vent and said at least one upper vent, so air flow from the pole continues up through said light fixture by natural convection.

14. A light as in claim 13, wherein the light fixture further comprises column units each comprising multiple of said plurality of LEDs arranged in a column, and each column unit having cooling fins extending into the internal space of the light fixture for cooling the LEDs.

15. A light as in claim 13, further comprising a control board located in the internal space of the light fixture.

16. A light as in claim 15, wherein said control board comprises electronics adapted to control charging of said storage device by the flexible panel, and also to control discharging of said storage device to light said light fixture.

17. A light as in claim 12, wherein said storage device comprises at least one battery, and the pole comprises a pole wall and an axial sleeve between the pole wall and the at least one battery, there being an annular space between said pole wall and the axial sleeve wherein said annular space is said interior air flow space of the pole.

18. A light as in claim 12, further comprising a decorative light fixture comprising no light source.

19. A light as in claim 12, further comprising a decorative light fixture comprising only a single LED powered by energy from said storage device.

20. A light as in claim 12, wherein said pole comprises a lower section and a middle section, wherein the storage device is contained within the lower section of the pole, said light fixture is connected to a top end of the middle section, and wherein the light fixture is generally cylindrical and coaxial with, and of the same diameter as, the middle section of the pole.

21. A light as in claim 20, wherein said lower section has a larger diameter than the diameter of the middle section and said lower section contains the storage device.

22. A light as in claim 17, further comprising a connection to a utility power grid for providing electricity to said power grid during daylight hours.

23. An outdoor light comprising:
 - a pole having a right cylindrical section with an outer surface having a circumference;

a flexible panel of amorphous photovoltaic material adhesively connected to said outer surface so that the flexible panel curves at least 225 degrees around the cylindrical section;

a cylindrical light fixture comprising a plurality of light-emitting-diodes (LEDs), wherein the light fixture extends coaxially from a top end of said pole; and

an energy storage device operatively connected to said flexible panel so that, when sunlight hits said flexible panel, resulting electrical energy is stored in said storage device; and

wherein said pole comprises at least one lower pole vent and said light fixture comprises at least one upper vent, and said pole and said light fixture comprise internal air flow passages in fluid communication with said at least one lower pole vent and said at least one upper vent, so that the pole and the light fixture are ventilated by a natural updraft of air flow through the internal air flow passages.

24. An outdoor light as in claim **23**, wherein said cylindrical light fixture has a fixture circumference and comprises at least two columns of LEDs spaced around the fixture circumference, and wherein each of said at least two columns each comprise at least four LEDs.

25. An LED light fixture comprising:

a generally cylindrical housing;

a plurality of axial column units connected to said housing and having a plurality of light-emitting diodes (LEDs) arranged axially in each column unit; and

said housing having an interior space;

cooling fins extending from each of said axial column units into the interior space for cooling said plurality of LEDs.

26. A light fixture as in claim **25**, further comprising an electronics control board received in said interior space of the housing.

27. A light fixture as in claim **25**, wherein said housing has at least one lower vent into the housing and at least one upper vent into the housing, said at least one lower vent and at least one upper vent being in fluid communication with said interior space of the housing, so that the housing is adapted for air flow up through the interior space to cool said LEDs.

28. A solar-powered pole comprising:

a pole wall having an outer surface and a circumference;

a flexible panel of amorphous photovoltaic material adhesively connected to said outer surface;

an energy storage device operatively connected to said flexible panel so that, when sunlight hits said flexible panel, resulting electrical energy is stored in said storage device, wherein said energy storage device is located inside the pole; and

wherein said pole comprises at least one lower pole vent, at least one upper pole vent, and an interior air flow space in fluid communication with said at least one lower pole vent and said at least one upper pole vent, so that a draft is created up through said interior air flow space to cool the pole.

29. A solar-powered pole as in claim **28**, further comprising an axial sleeve within at least a portion of the pole creating an annular air flow space that is said interior air flow space.

30. A solar-powered pole as in claim **29**, wherein said storage device is a battery that is contained inside said sleeve.

* * * * *